

Sabin chain[®]

nsb-S : Sliding Type

■ nsb050S	341p
■ nsb065S	346p
■ nsb080S	351p

» Details of nsb Sliding Type

A New sabin chain is totally new sliding type which has low dust with noiseless movement.

B This sliding type has united skid with its side band unlike Shift chains, which come to save the time for assembling. This type is designed for gantry loader application which has fast movement with lower friction.

C The same material with easy shape without any gap between nylon bar to bar, bump on sides of skid will reduce noise as well as dust.

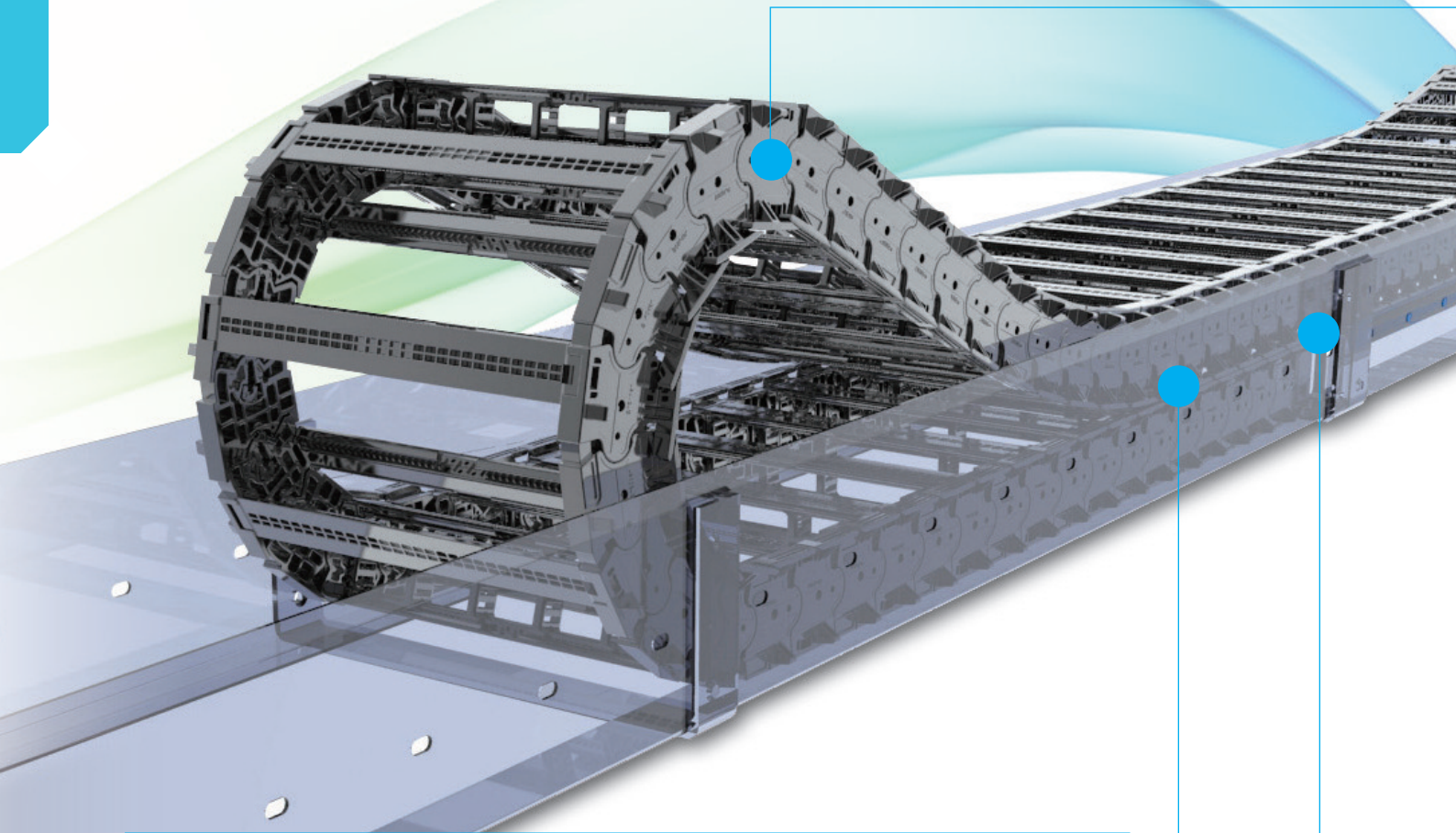

6

The height of Side Band and End Bracket makes equal which will make straight path through Nylon Bar. This will reduce the sound as well dust.

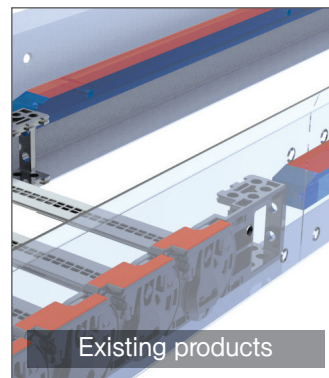
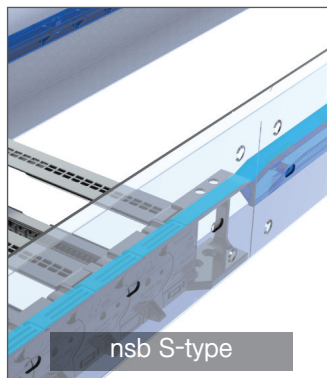

1

To minimize dust, unnecessary friction surface has been reduced.

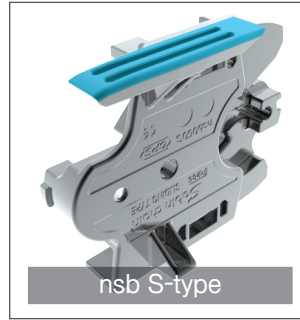

2

Due to integral structure, assembling time can be reduced and it is very suitable for high speed driving.

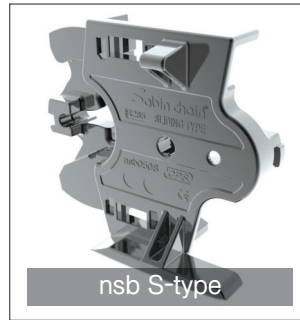

3

Supporting fixture has been added to keep the stable inside Guide channel.

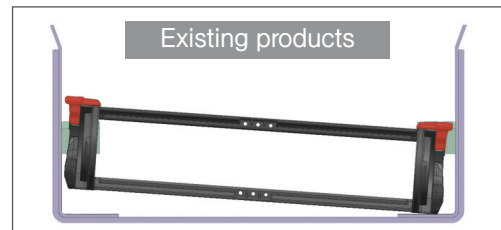
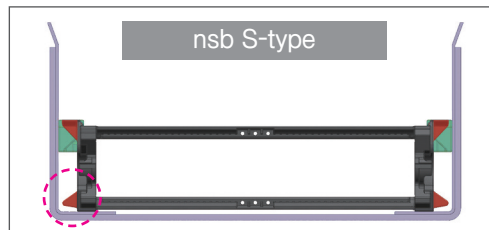

4

It works smoothly and is highly suitable for noise regulated work place due to reduced interval between skids.

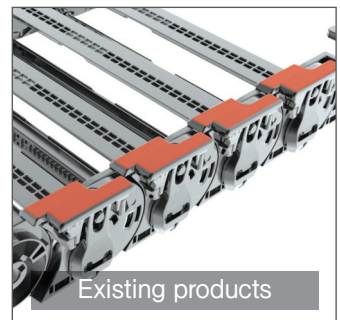
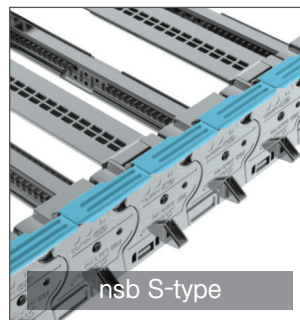

5

Making the groove on skid surface can minimize dust and interference with Guide Channel during the chain movement.

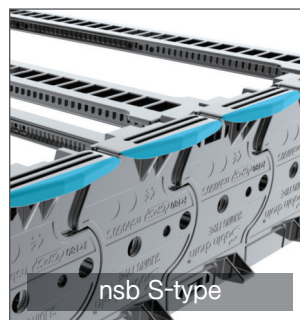



nsb 050S, 065S, 080S | SLIDING Type

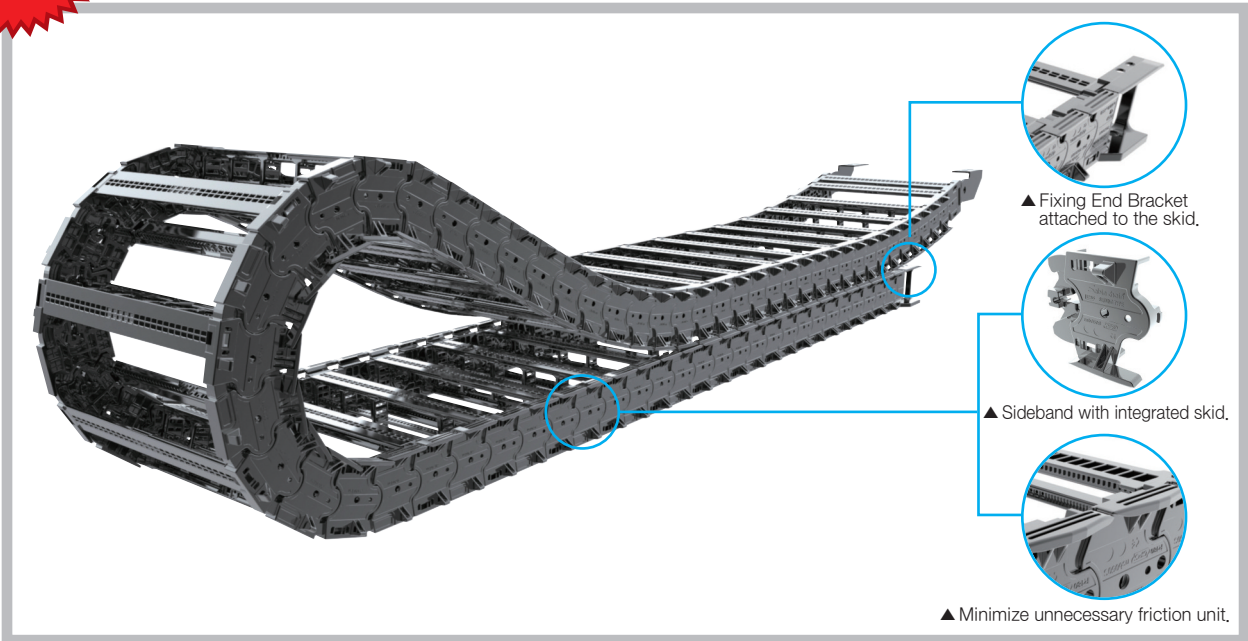

- Chain material
: CPS-amide, UL94-HB
- Temperature
: -30°C ~ +130°C
- Maximum Speed
: 3m / sec
- Acceleration
: 10m / s²

■ Calculation of the chain length

$$\left[L = \frac{L_s}{2} + L_p \right]$$

■ Installation Length

$$L_s = 50m \quad \left[\frac{L_s}{2} = 25m \right]$$

※ If you need it over 50m, please contact headquarters.

■ Applications

Low noise, Low dust, facilities and equipments requiring a long travel distance as below ; Gantry Robots, Robot Carriages, Automatic Welding Lines, Gantry Cranes, Gantry loader etc.

📌 BRACKET TYPE

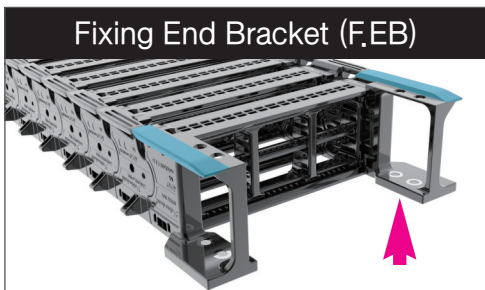

The height of Side Band and End Bracket makes equal which will make straight path through Nylon Bar. This will reduce the sound as well dust.

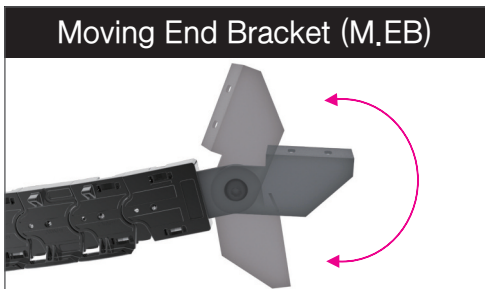

The moving bracket is designed to move up and down as the cable chain or application requires. Moving End Brackets substitute the steel plate being used by competitors to elevate the moving end for long stroke applications. And it is possible to be installed B1, B2 types of brackets.

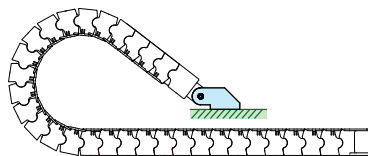

B1

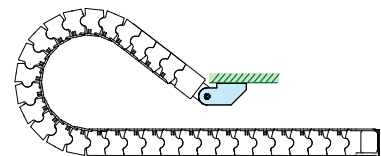

B2

! Above products are patent registered item which can be protected by industrial property right.

⇩ DIVIDERS

Dividers (Vertical) and Separators (Horizontal) divide the inner chamber of the cable chain to give each cable diameter its own center and keep the cables separated from each other. The use of a separator in some cases, can also reduce the width requirements as two or more levels can be made within the same chamber. To prevent twisting or damage to the cables, as a rule, there needs to be at least 10% space between the inserted cable and its enclosure.

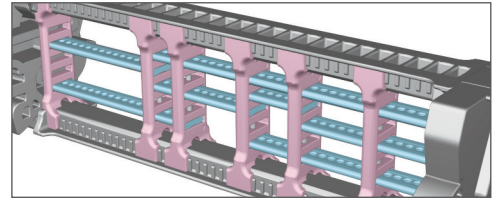

⇩ SEPARATORS

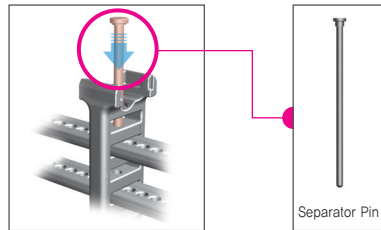
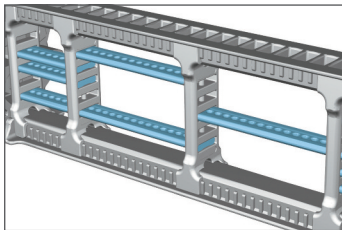

Separator is available in length from 20mm to 600mm and can be cut every 5mm for use. The combined use of divider and separator with the pin creates the most effective cable pattern and keep insertion space for cables safely, so it protects the inserted cables.

⇩ TIE WRAP

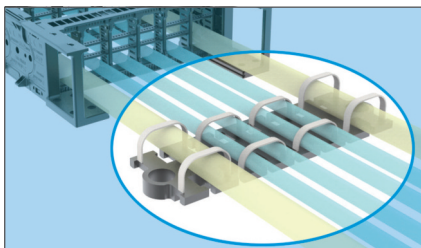

The tie wrap separated from the nsb Chain bracket, when installed properly, protects the inserted cables from becoming entangled and twisted during operation.

SYSTEM TIE WRAP

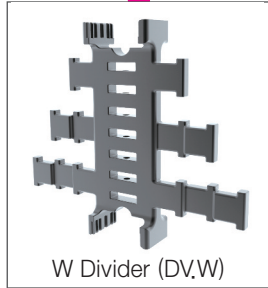
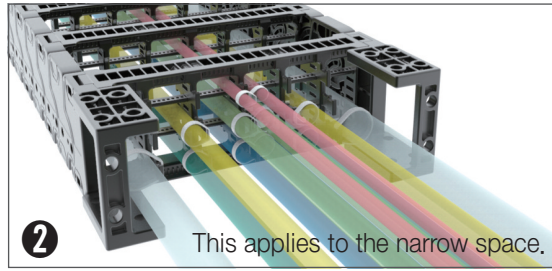
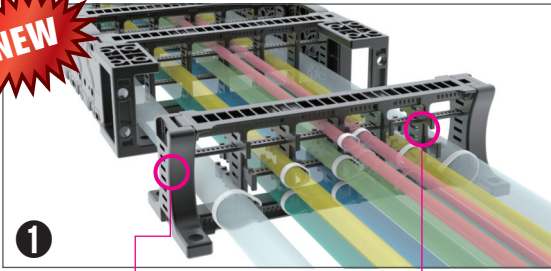

System-Tie Wrap has to be assembled on fixing and moving point of bracket and can be assembled without any tie wrap plate. This tie wrap is used to stay the cables on several floors prevent the cables from being twisting and it can also be assemble without any tools or bolt. This tie wrap has two types, one is 1 outside the other one is 2 to assemble inside bracket.

GUIDE CHANNEL

For long stroke applications the guide channel is applied to ensure that the nsb chain S-Type stays on track and to ensure safety during operation. With the application of a rubber pad on the channel floor, noise is reduced to a minimum. Guide channels are made of Steel+Zn and can be customized with SUS material.

! Thickness can be changed by the product standards of material.

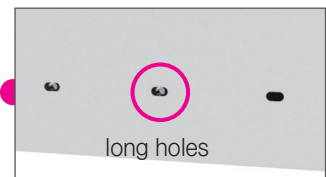
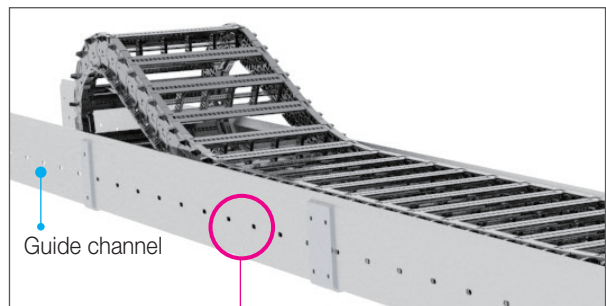

nsb 050S | Sliding Type

CHAIN CROSS SECTION

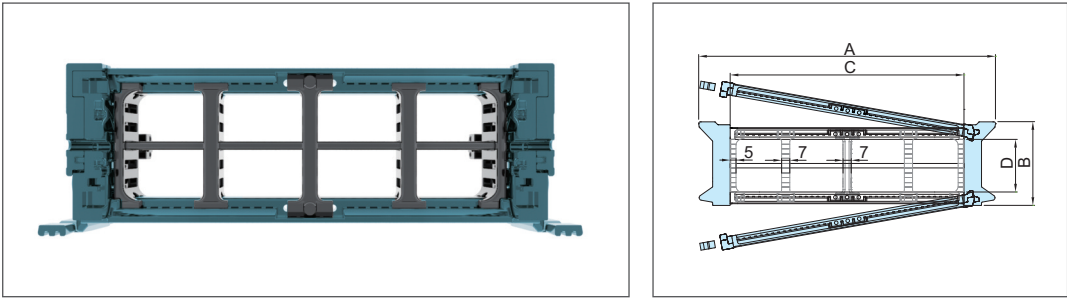

Chain Type	A Width (Outer)	B Height (Outer)	C Frame	D Height (Inner)	Weight kg/m
nsb 050S	104	71.5	50	45	2.38
	129		75		2.44
	154		100		2.51
	179		125		2.61
	194		140		2.67
	204		150		2.71
	219		165		2.76
	229		175		2.80
	244		190		2.97
	254		200		3.09
	294		240		3.32
	304		250		3.38
	354		300		3.63

(Dimensions in mm)

LAYOUT OF THE CHAIN

Ls: Stroke

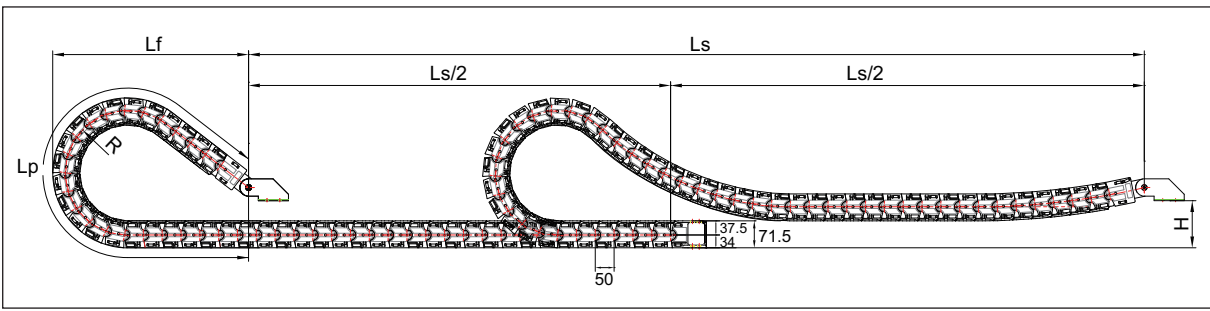

Bending Radius (R)	Lp Loop Length	Lf Loof Projection	H Moving Height
110	916	380	180
135	1,068	430	
165	1,255	490	
185	1,382	530	
235	1,703	630	
285	2,029	730	

(Dimensions in mm)

SABIN CHAIN

FREE END BRACKET

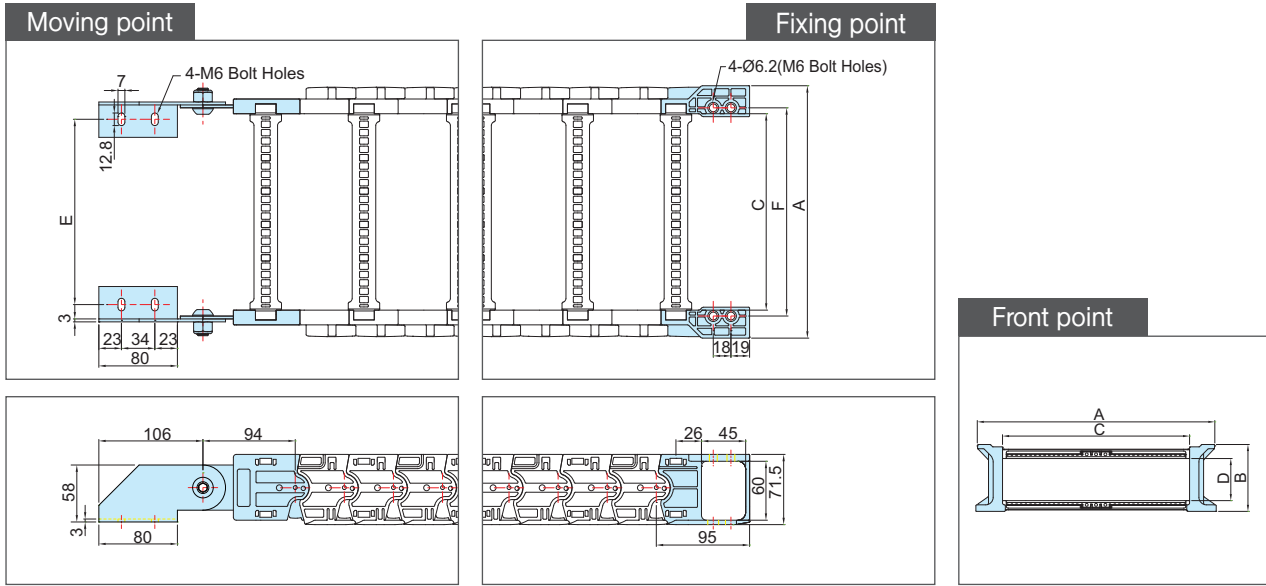

Chain Type	A Width (Outer)	B Height (Outer)	C Frame	D Height (Inner)	E M,EB Bolt hole width	F F,EB Bolt hole width
nsb 050S	104	71.5	50	45	38.7	62
	129		75		63.7	87
	154		100		88.7	112
	179		125		113.7	137
	194		140		128.7	152
	204		150		138.7	162
	219		165		153.7	177
	229		175		163.7	187
	244		190		178.7	202
	254		200		188.7	212
	294		240		228.7	252
	304		250		238.7	262
354	300	288.7	312			

(Dimensions in mm)

ORDERING

nsb 050S. 175. R185 / B1 - 10000L : 10ST



- Q'ty(set)
- Length(mm)
- End Bracket : B1, B2
- T : Tie Wrap
- S : System Tie Wrap
- Bending Radius
- Inside Width
- Sliding Type (S)
- New Sabin Chain

⬇️ DIVIDERS (DV)

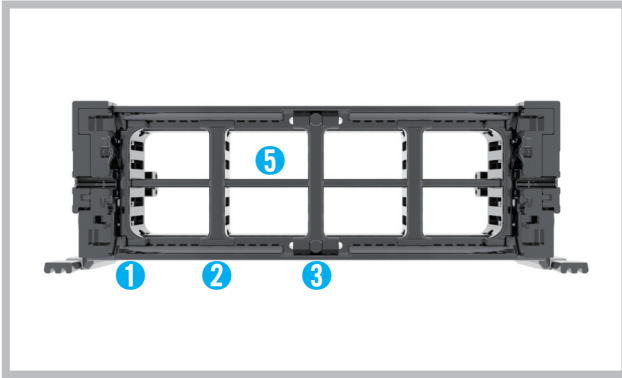

Assemble divider every Four links.
 DV.T : Applied to Frame 200~300.
 DV.W : Applicable to System Tie Wrap or FEB.

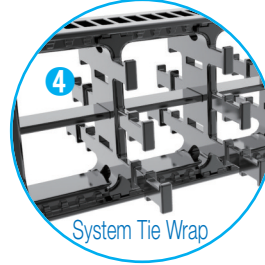

1 DV07.S

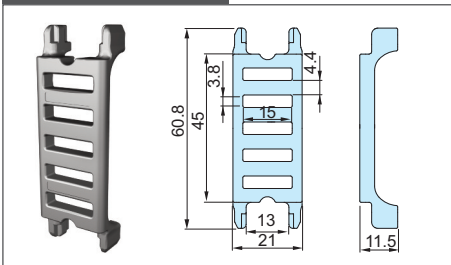

2 DV07.M

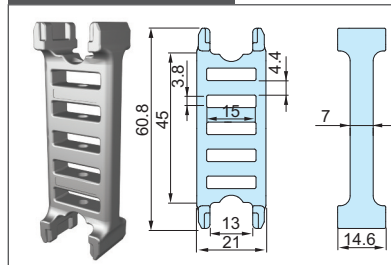

3 DV07.T

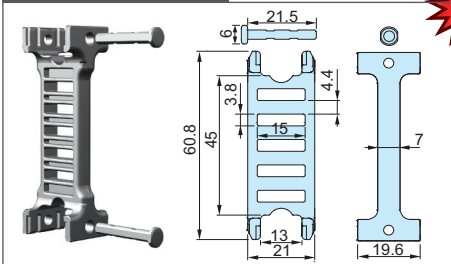

4 DV07.W

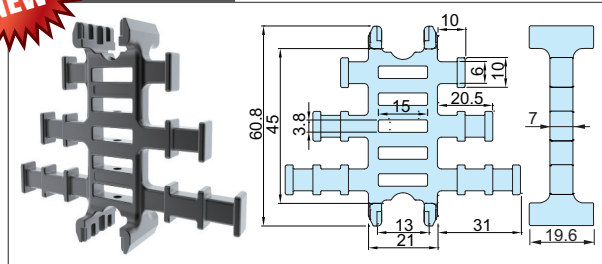

(Dimensions in mm)

⬇️ SEPARATORS (SP)

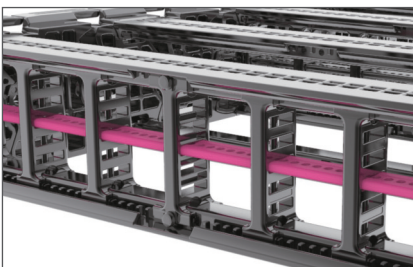

5 SP02 : Can order according to desired length of section.

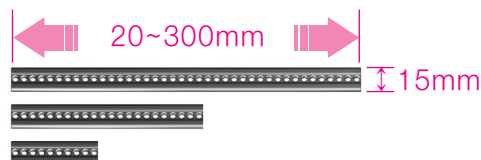

TIE WRAP (TW)

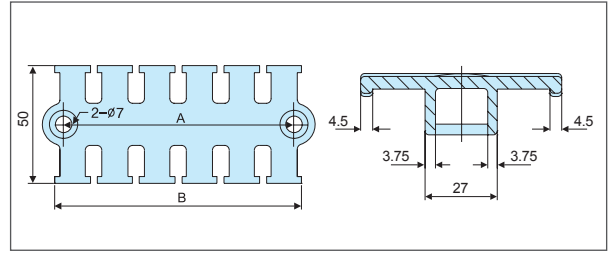
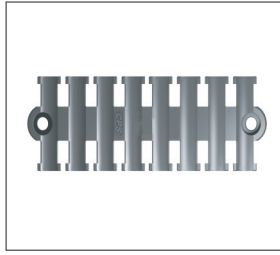
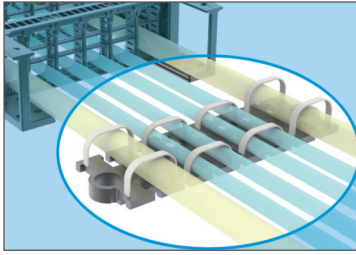

Chain Type	Ordering NO.	A	B
nsb 050S	TW05.050	58	65
	TW05.075	75	82
	TW05.100	98	105
	TW05.125	122	129
	TW05.150	141	148

(Dimensions in mm)

SYSTEM TIE WRAP (STW)

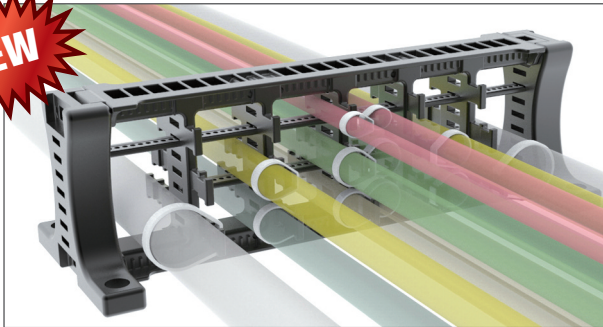

Size of separator and divider will change according to the size of frame and cables(hose).

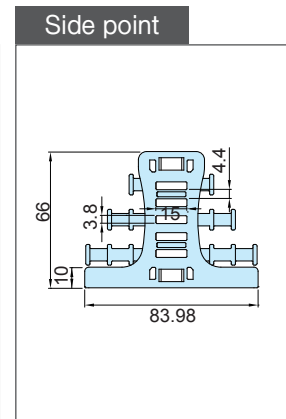
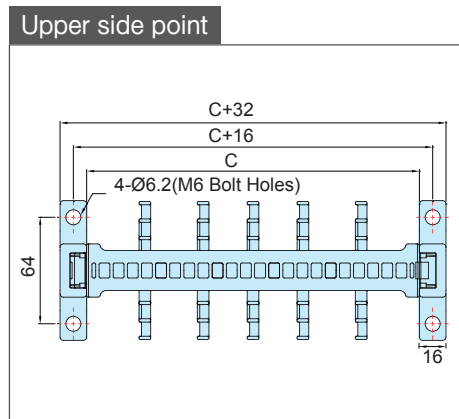
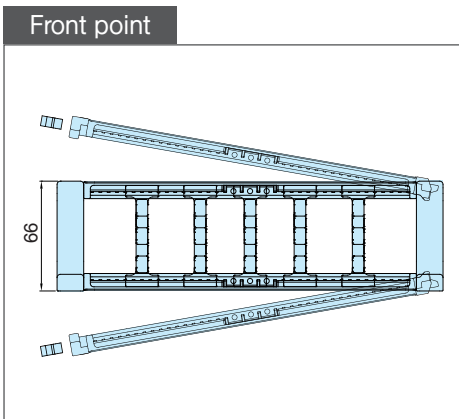

Chain Type	Ordering NO.	C Frame	Hole Type
nsb 050S	STW03.050	50	M6 Bolt Holes
	STW03.075	75	
	STW03.100	100	
	STW03.125	125	
	STW03.140	140	
	STW03.150	150	
	STW03.165	165	
	STW03.175	175	
	STW03.190	190	
	STW03.200	200	
	STW03.240	240	
	STW03.250	250	
	STW03.300	300	

(Dimensions in mm)

nsb 065S | Sliding Type

CHAIN CROSS SECTION

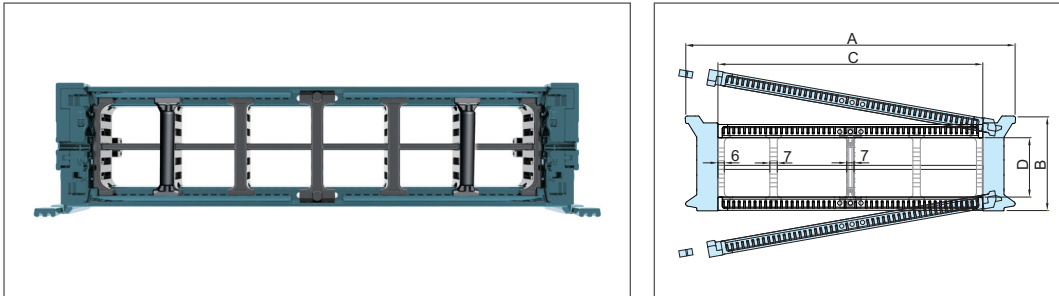

Chain Type	A Width (Outer)	B Height (Outer)	C Frame	D Height (Inner)	Weight kg/m
nsb 065S	137	89	75	56	3.29
	162		100		3.34
	187		125		3.49
	212		150		3.58
	237		175		3.68
	252		190		3.76
	262		200		3.82
	302		240		3.99
	312		250		4.03
	362		300		4.24
412	350	4.53			
462	400	4.85			

(Dimensions in mm)

LAYOUT OF THE CHAIN

Ls: Stroke

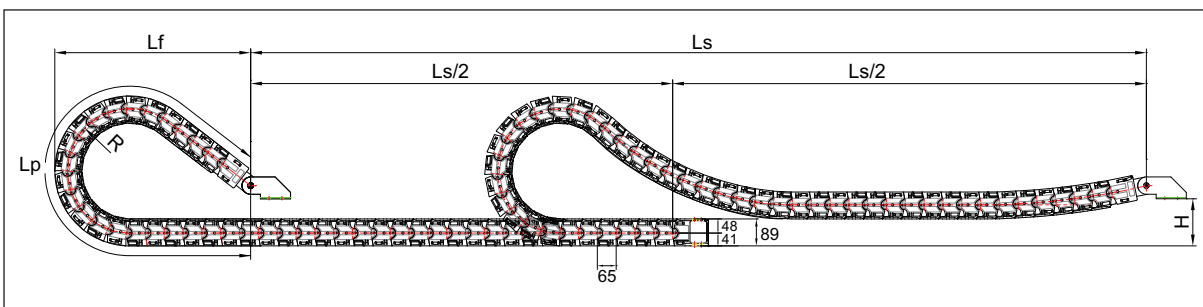

Bending Radius (R)	Lp Loop Length	Lf Loop Projection	H Moving Height
140	1,225	615	210
190	1,543	715	
220	1,734	775	
270	2,052	875	
390	2,814	1,115	

(Dimensions in mm)

FREE END BRACKET

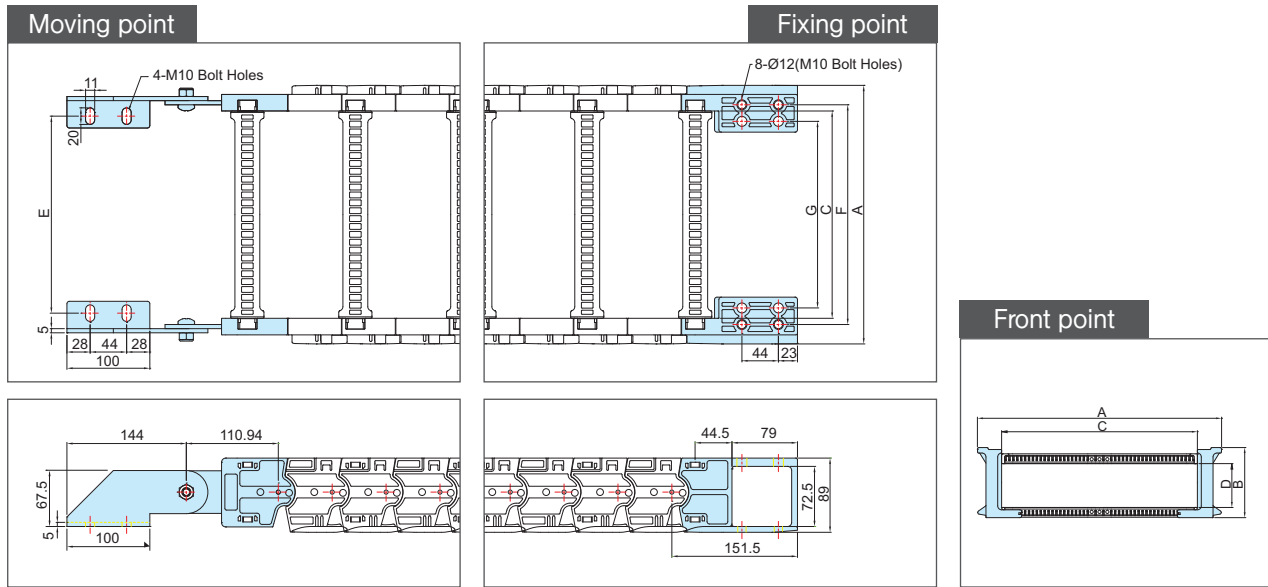

Chain Type	A Width (Outer)	B Height (Outer)	C Frame	D Height (Inner)	E M,EB Bolt hole width	F F,EB Bolt hole width	G F,EB Bolt width
nsb 065S	137	89	75	56	62.6	90	50
	162		100		87.6	115	75
	187		125		112.6	140	100
	212		150		137.6	165	125
	237		175		162.6	190	150
	252		190		177.6	205	165
	262		200		187.6	215	175
	302		240		227.6	255	215
	312		250		237.6	265	225
	362		300		287.6	315	275
412	350	337.6	365	325			
462	400	387.6	415	375			

(Dimensions in mm)

ORDERING

nsb 065S. 175. R190 / B1 - 10000L : 10ST



Q'ty(set)
 Length(mm)
 End Bracket : B1, B2
 T : Tie Wrap
 S : System Tie Wrap
 Bending Radius
 Inside Width
 Sliding Type (S)
 New Sabin Chain

↓ DIVIDERS (DV)

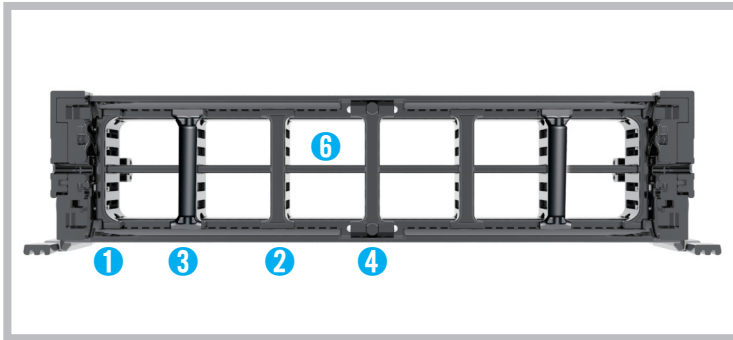

Assemble divider every Four links.
 DV.T : Applied to Frame 250~400
 DV.W : Applicable to System Tie Wrap or FEB.

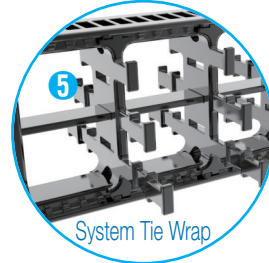

1 DV09.S

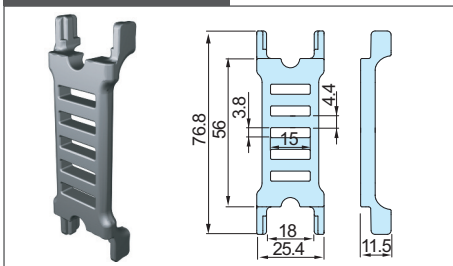

2 DV09.M

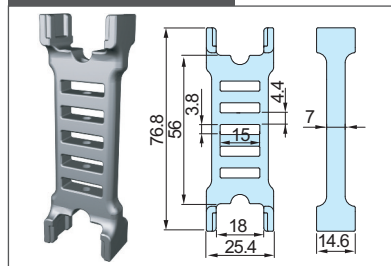

3 DV09.R

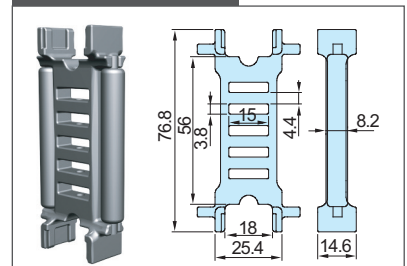

4 DV09.T

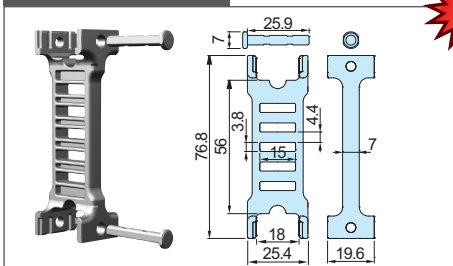

5 DV09.W

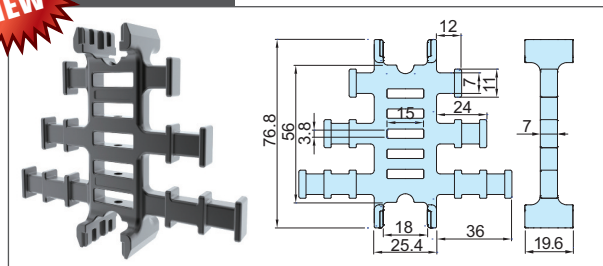

(Dimensions in mm)

↓ SEPARATORS (SP)

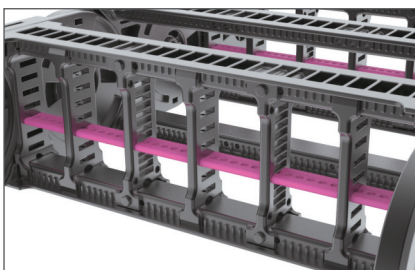

6 SP02 : Can order according to desired length of section.

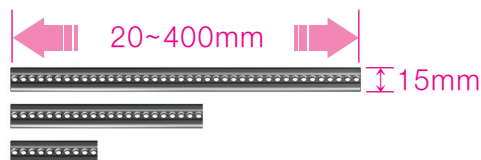

TIE WRAP (TW)

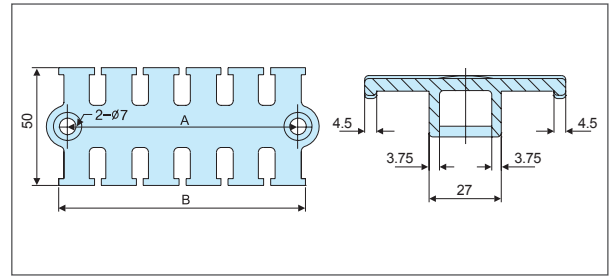
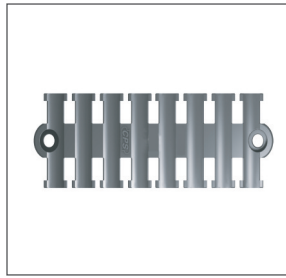
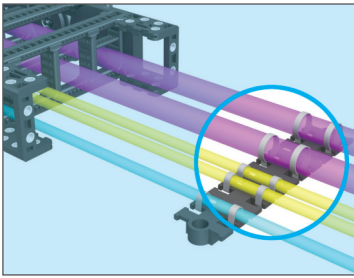

Chain Type	Ordering NO.	A	B
nsb 065S	TW05.050	58	65
	TW05.075	75	82
	TW05.100	98	105
	TW05.125	122	129
	TW05.150	141	148

(Dimensions in mm)

SYSTEM TIE WRAP (STW)

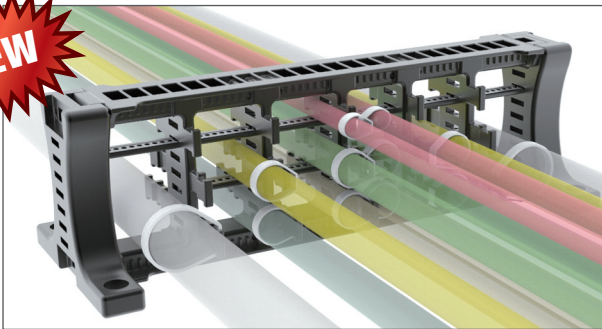

Size of separator and divider will change according to the size of frame and cables(hose).

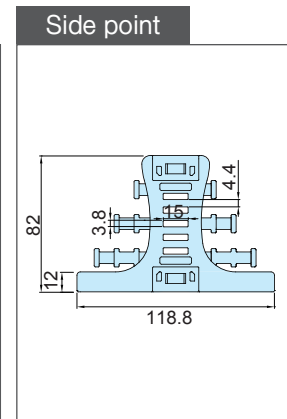
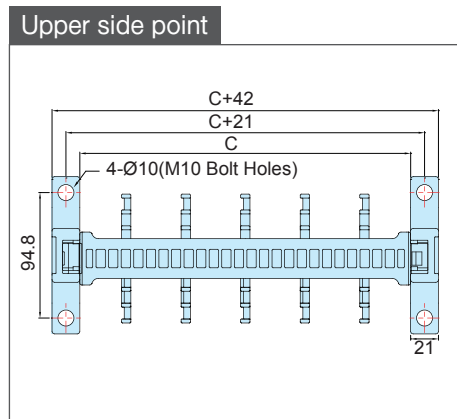
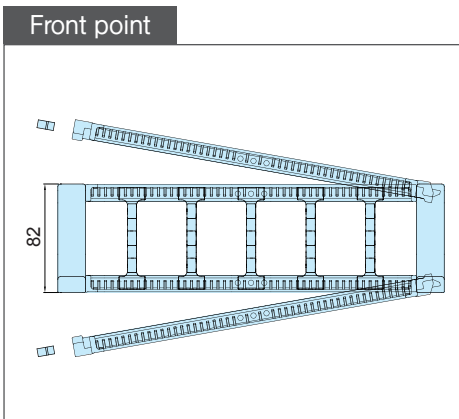

Chain Type	Ordering NO.	C Frame	Hole Type
nsb 065S	STW04.075	75	M10 Bolt Holes
	STW04.100	100	
	STW04.125	125	
	STW04.150	150	
	STW04.175	175	
	STW04.190	190	
	STW04.200	200	
	STW04.240	240	
	STW04.250	250	
	STW04.300	300	
	STW04.350	350	
	STW04.400	400	

(Dimensions in mm)

GUIDE CHANNEL

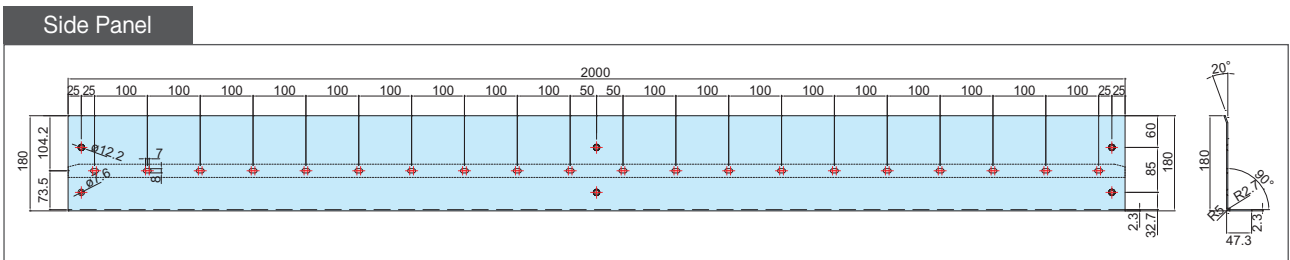
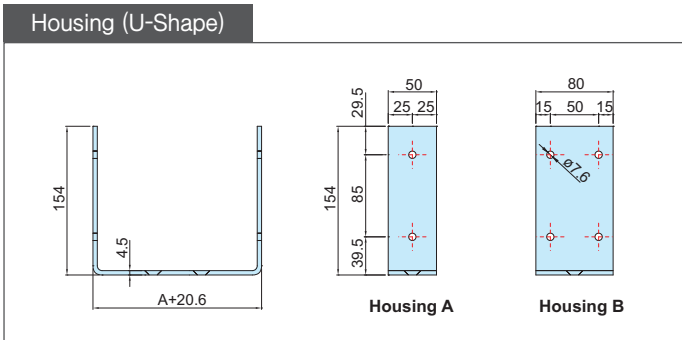
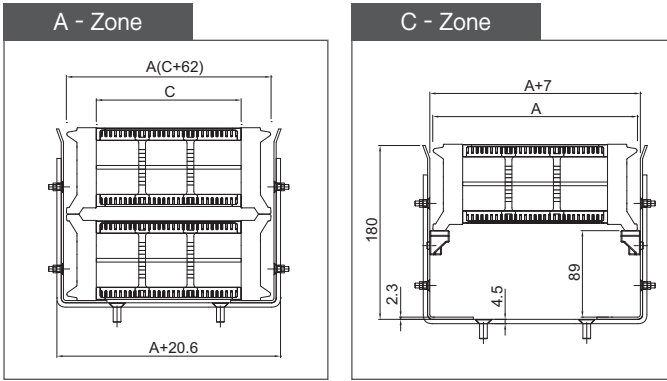

(Dimensions in mm)

GUIDE CHANNEL ORDERING

nsb-GCS 065S. 100 / A,C : 200M



nsb 080S | Sliding Type

CHAIN CROSS SECTION

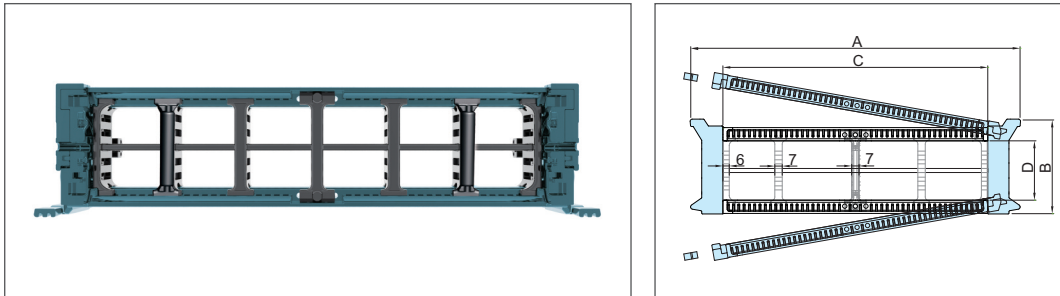

Chain Type	A Width (Outer)	B Height (Outer)	C Frame	D Height (Inner)	Weight kg/m
nsb 080S	143	115	75	78	4.27
	168		100		4.36
	183		115		4.43
	193		125		4.47
	218		150		4.57
	243		175		4.67
	268		200		4.85
	308		240		5.03
	318		250		5.07
	358		290		5.33
	368		300		5.40
	418		350		5.71
	468		400		6.09
	518		450		6.28
	568		500		6.45
618	550	7.08			
668	600	7.20			

(Dimensions in mm)

LAYOUT OF THE CHAIN

Ls: Stroke

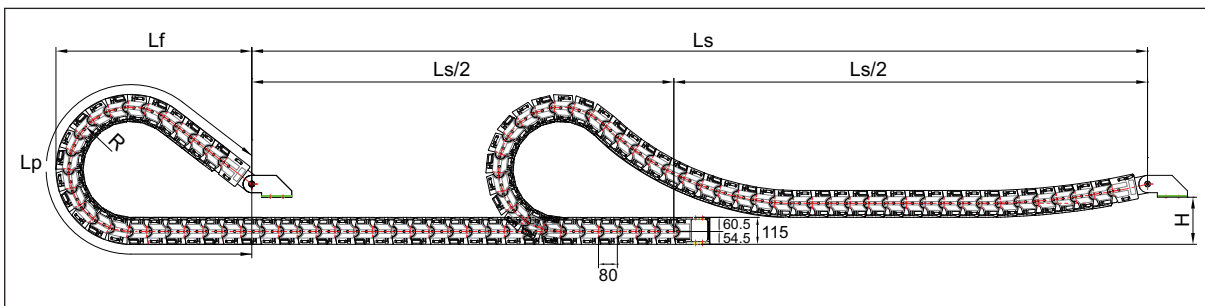

Bending Radius (R)	Lp Loop Length	Lf Loof Projection	H Moving Height
180	1,490	690	260
200	1,617	730	
250	1,935	830	
300	2,253	930	
350	2,571	1,030	
400	2,889	1,130	
500	3,524	1,330	

(Dimensions in mm)

SABIN CHAIN

FREE END BRACKET

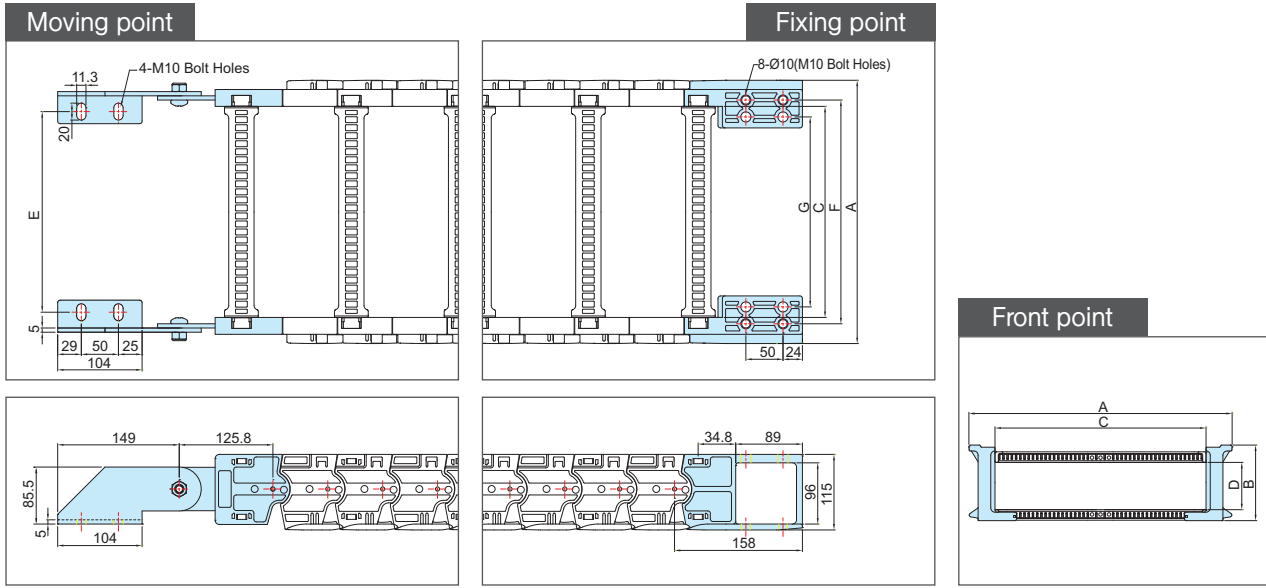

Chain Type	A Width (Outer)	B Height (Outer)	C Frame	D Height (Inner)	E M,EB Bolt hole width	F F,EB Bolt hole width	G F,EB Bolt width
nsb 080S	143	115	75	78	63	104	47
	168		100		88	129	72
	183		115		103	144	87
	193		125		113	154	97
	218		150		138	179	122
	243		175		163	204	147
	268		200		188	229	172
	308		240		228	269	212
	318		250		238	279	222
	358		290		278	319	262
	368		300		288	329	272
	418		350		338	379	322
	468		400		388	429	372
	518		450		438	479	422
	568		500		488	529	472
	618		550		538	579	522
668	600	588	629	572			

(Dimensions in mm)

ORDERING

nsb 080S. 175. R200 / B1 - 10000L : 10ST

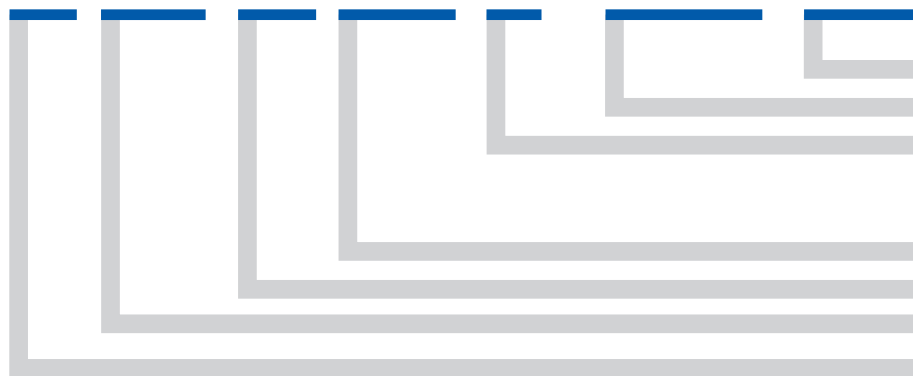

- Q'ty(set)
- Length(mm)
- End Bracket : B1, B2
- T : Tie Wrap
- S : System Tie Wrap
- Bending Radius
- Inside Width
- Sliding Type (S)
- New Sabin Chain

⇩ DIVIDERS (DV)

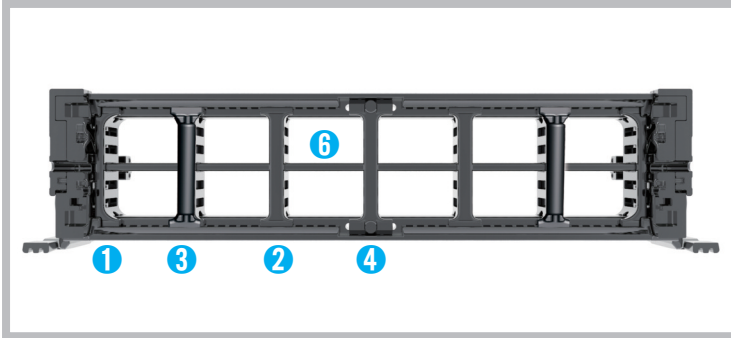

Assemble divider every Two links.
 DV.T : Applied to Frame 300~600
 DV.W : Applicable to System Tie Wrap or FEB.

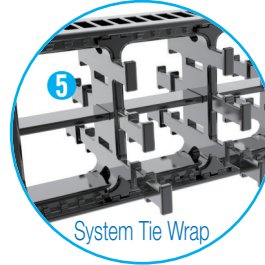

① DV10.S

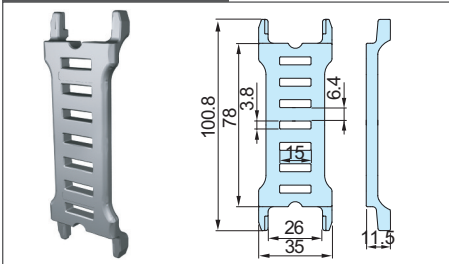

② DV10.M

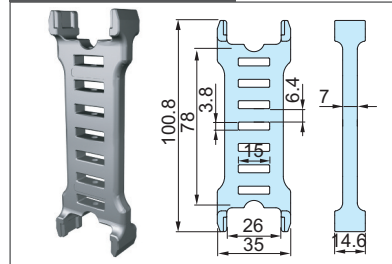

③ DV10.R

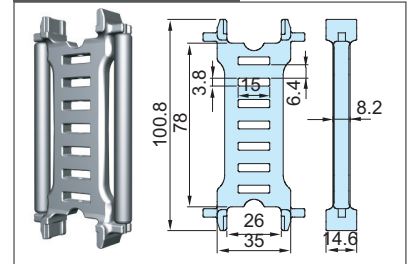

④ DV10.T

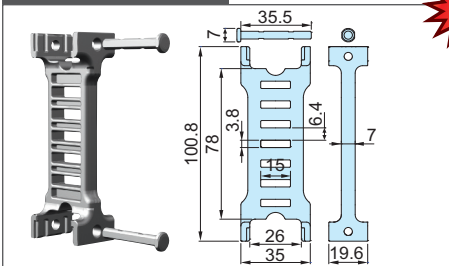

⑤ DV10.W

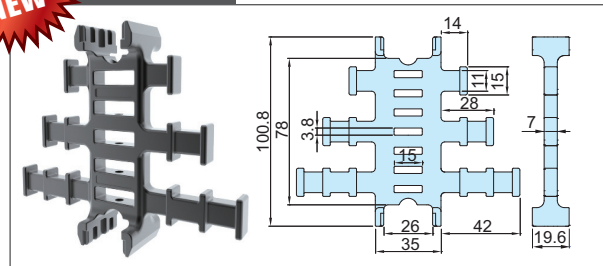

(Dimensions in mm)

⇩ SEPARATORS (SP)

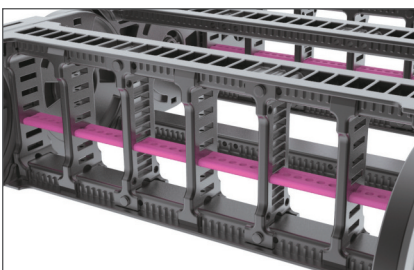

⑥ SP02 : Can order according to desired length of section.

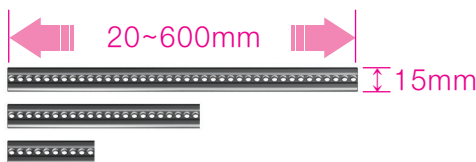

⇩ TIE WRAP (TW)

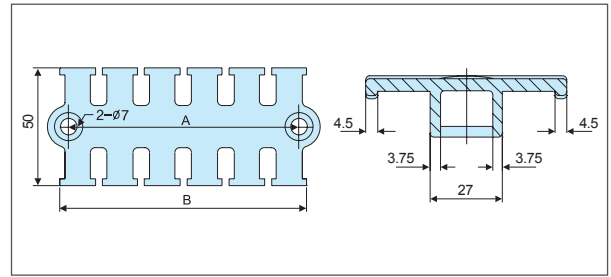
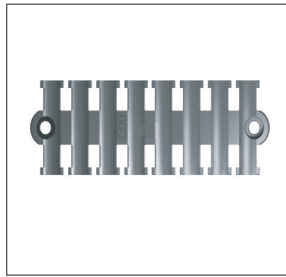
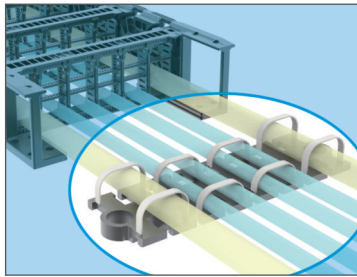

Chain Type	Ordering NO.	A	B
nsb 080S	TW05.050	58	65
	TW05.075	75	82
	TW05.100	98	105
	TW05.125	122	129
	TW05.150	141	148

(Dimensions in mm)

⇩ SYSTEM TIE WRAP (STW)

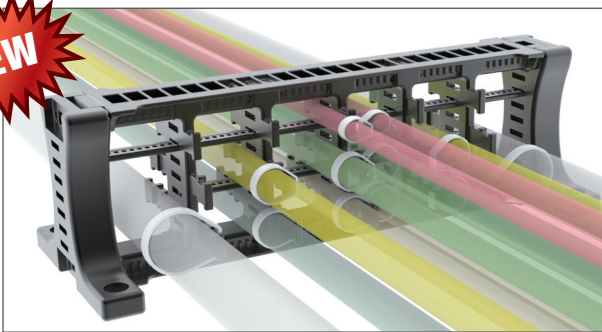

Size of separator and divider will change according to the size of frame and cables(hose).

Front point

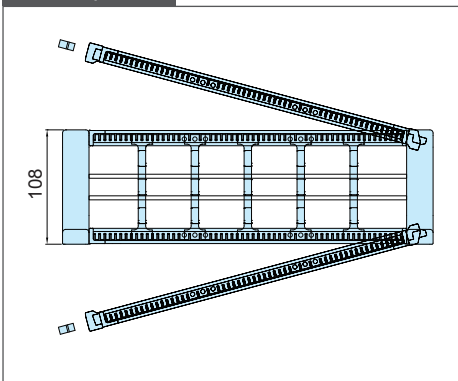

Upper side point

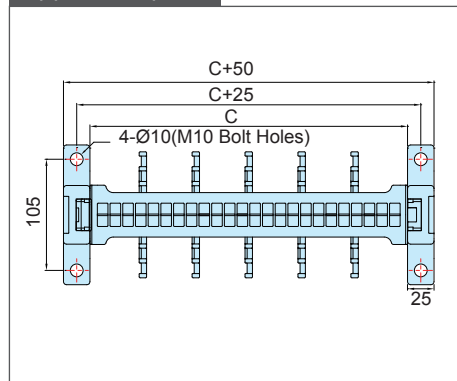

Side point

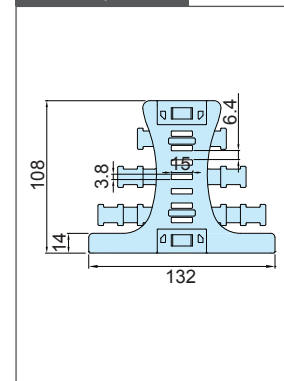

Chain Type	Ordering NO.	C Frame	Hole Type
nsb 080S	STW05.075	75	M10 Bolt Holes
	STW05.100	100	
	STW05.115	115	
	STW05.125	125	
	STW05.150	150	
	STW05.175	175	
	STW05.200	200	
	STW05.240	240	
	STW05.250	250	
	STW05.290	290	
	STW05.300	300	
	STW05.350	350	
	STW05.400	400	
	STW05.450	450	
	STW05.500	500	
	STW05.550	550	
STW05.600	600		

(Dimensions in mm)

GUIDE CHANNEL

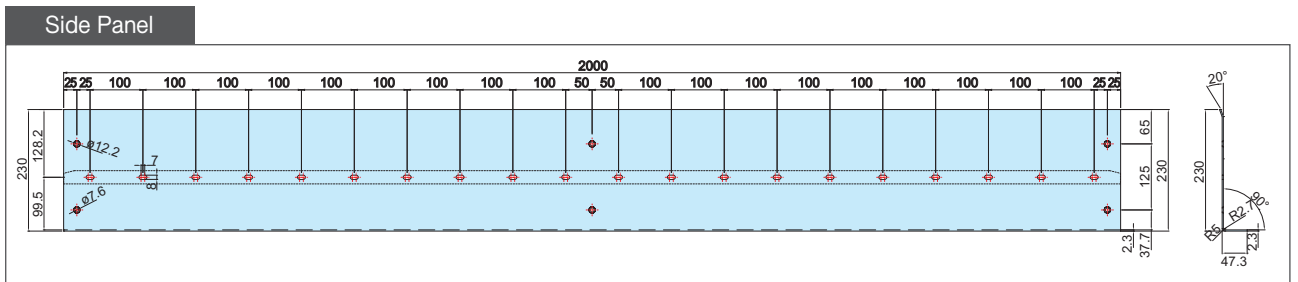
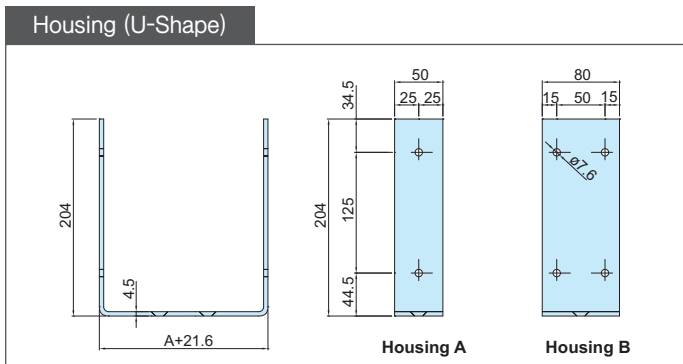
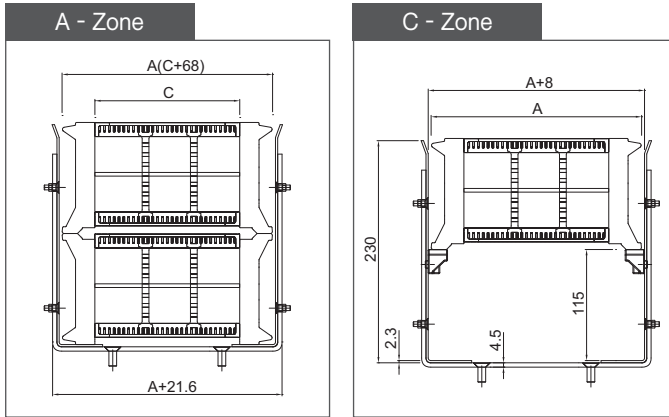

(Dimensions in mm)

GUIDE CHANNEL ORDERING

nsb-GCS 080S. 100 / A,C : 200M



ASSEMBLY PROCEDURE / nsb Sliding Type

The assembling process of S-Type of New Sabin Chain is like below and you must use rubber hammer with careful combination of Divider and Separator.

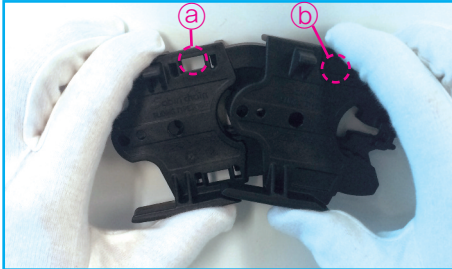

1

Classify LH and RH first, then assemble the Side band.
(Assemble from ① to ② according to priority)



2

Connect the Side Band by the needed length.



3

Install F,EB according to the right and left direction.

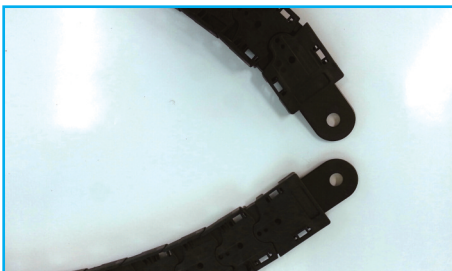

4

Install M,EB according to the right and left direction.

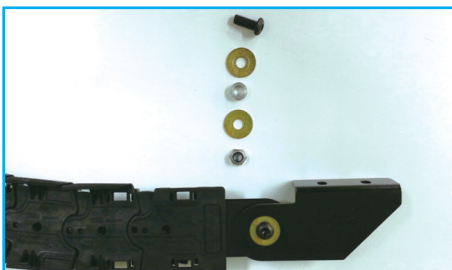

5

Assemble the Steel Bracket on the M,EB by tightening bolt and nut.
(Bolt → flat washer → insert steel → flat washer → Nut)

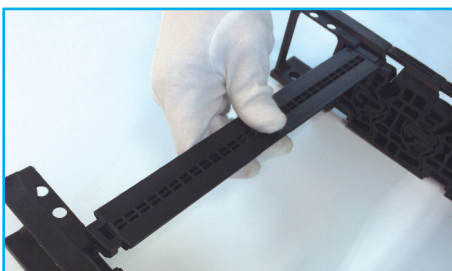

6

Assemble the left and right Side Band on specified frame.

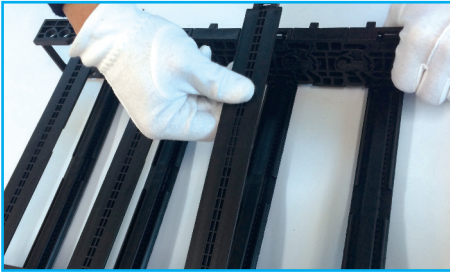

7

Frame in the opposite direction also assemble in the same manner.

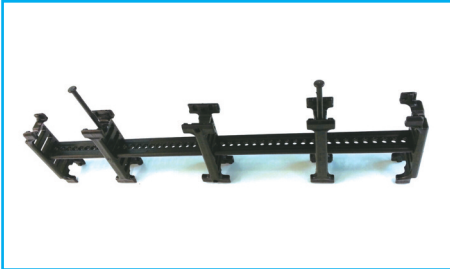

8

Install the separators on dividers then fix by separate pin.



9

Fix the dividers on lower frame. (Assemble divider every Four links)



10

Combine the upper frame exactly on the groove of sideband and divider.



11

Fix the frame and side band by using the frame pin.

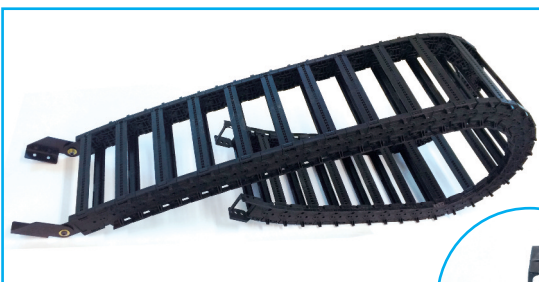

12

Complete by inserting the reinforce washer to fit in direction of F,EB fixing.

